

Conveyor chains (MT series)

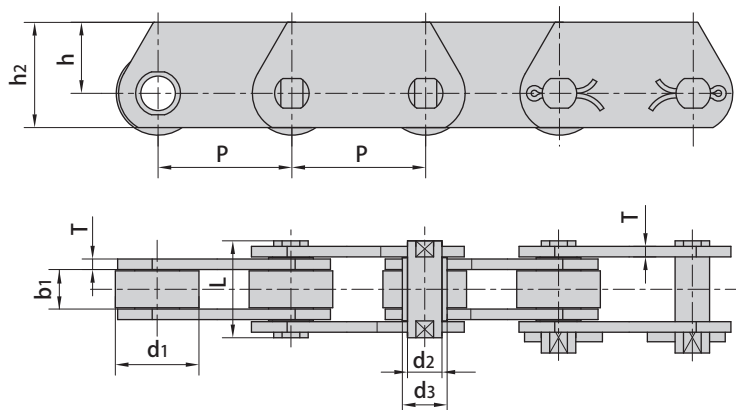

DIN Chain No.	Pitch					Roller diameter	Pin diameter	Bush diameter	Plate thickness
	P					d1 max	d2 max	d3 max	T max
	mm					mm	mm	mm	mm
MT20	40.0	50.0	63.0	80.0	100.0	25.0	6.0	9.0	2.5
MT28	50.0	63.0	80.0	100.0	125.0	30.0	7.0	10.0	3.0
MT40	63.0	80.0	100.0	125.0	160.0	36.0	8.5	12.5	3.5
MT56	63.0	80.0	100.0	125.0	160.0	42.0	10.0	15.0	4.0
MT80	80.0	100.0	125.0	160.0	200.0	50.0	12.0	18.0	5.0
MT112	80.0	100.0	125.0	160.0	200.0	60.0	15.0	21.0	6.0
MT160	100.0	125.0	160.0	200.0	250.0	70.0	18.0	25.0	7.0
MT224	125.0	160.0	200.0	250.0	315.0	85.0	21.0	30.0	8.0
MT315	160.0	200.0	250.0	315.0	400.0	100.0	25.0	36.0	10.0
MT450	200.0	250.0	315.0	400.0	500.0	120.0	30.0	42.0	12.0

DIN Chain No.	Width between inner plates	Pin length	Plate depth		Ultimate tensile strength	
	b1 min	L max	h2 max	h max	Q min	*Q min
	mm	mm	mm	mm	kN/lbf	kN/lbf
MT20	16.0	35.0	25.0	16.0	20.0/4545	32.0/7270
MT28	18.0	40.0	30.0	20.0	28.0/6364	42.0/9545
MT40	20.0	45.0	35.0	22.5	40.0/9091	60.0/13635
MT56	24.0	52.0	45.0	30.0	56.0/12727	85.0/19318
MT80	28.0	62.0	50.0	32.5	80.0/18182	125.0/28408
MT112	32.0	73.0	60.0	40.0	112.0/25454	175.0/39768
MT160	37.0	85.0	70.0	45.0	160.0/36364	260.0/59090
MT224	43.0	98.0	90.0	60.0	224.0/50909	340.0/77272
MT315	48.0	112.0	100.0	65.0	315.0/71591	520.0/118180
MT450	56.0	135.0	120.0	80.0	450.0/102272	700.0/159089

*Q denotes the ultimate tensile strength after hardened